

SAPIF 4th meeting  
Working Group Leaders/CoLeaders only  
Tues 09 July 2019

**robust**details®



BEIS: Ally Rae

BRE: John Henderson and Will Griffiths

RDL: John Tebbit (Chair) and Nick Booth

Rev 2.0 (reduced to 1.2MB)

Open - so anyone can view

# Agenda



- |               |  |
|---------------|--|
| 10.00 – 10.20 | Introductions etc<br>BEIS policy update<br>Meeting objectives            |
| 10.20 – 11.20 | WGs presentations<br>#1 (DHW), #2 (S.Controls) and #3 (H.Energy storage) |
| 11.20 – 11.35 | break  |
| 11.35 – 12.15 | WGs presentations<br>#4 (O/heating) and #5 (Vent +IAQ)                   |
| 12.15 - 12.45 | Q&A session  |
| 12.45 – 13.00 | Possible dates for next meeting in Oct and Summary                       |



## As a reminder:

- SAPIF is a joint RDL / BRE group
- This work feeds into SAP11 and for technologies that will be available in mid-2020s onwards
- 5 WGs Leaders / CoLeaders gave an update at last SAPIF meeting
- The work of the 5 WGs will contribute toward 'The Building Mission'
- Timeframe is end Q1 2020 for submissions

# The next steps



What would you like .....

What is the timeline .....

What are the outputs .....

Future SAPIF meeting(s) .... Objectives .....

October	Open to all	“How are we doing?”
January 2020	Open to all	“Last chance before handover”
March 2020	Leaders / CoLeaders only	Presentation of findings

# BEIS – Ally Rae

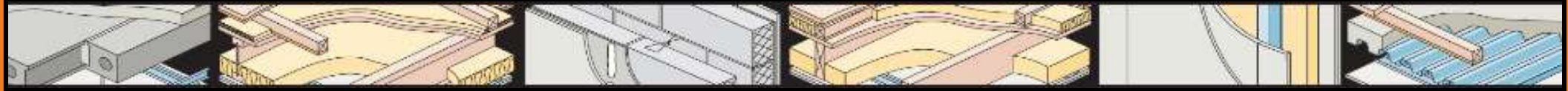

# Up-to-date policy context

Buildings Mission, to at least halve the energy use of new buildings by 2030 (England only)

Future Homes Standard by 2025: new build homes to have low carbon heating and world-leading levels of energy efficiency (England)



Improve the EPC of fuel poor and private rented households to Band C by 2030 (England only)

Commitment to bring the EPC rating for all homes to Band C by 2035 (England)

Phase out fossil fuel heating off the gas grid during the 2020s (territorial extent depends on policy levers)

Part L and SAP 10

SAP 11

Commitment for  
Less, Energy  
Industrial Strategy

# Working Groups



# Working Groups' overall objectives



The main objectives for the working groups set up by SAPIF are:

1. To establish the state of the art, sources of info. and basic explanations of the technologies/systems expected to be mature in the mid-2020s.
  2. To propose some modelling criteria for the performance of the technologies; and secondly how compliance could be judged at both product and dwelling level.
  3. If government decides to include recognition of the technology or system in SAP11, to work with government and the SAP contractor to develop the details. Note that the inclusion of any technology in a WG does not mean that it will necessarily be included in a future version of SAP.
- Detailed generic outputs (6 no.) for each WG issued
  - Part L is not in scope



# Working Groups



## **#1 Domestic Hot Water, heating and 1-day hot water storage**

Steven Sutton (HHIC) and Jeff House (Building Alliance)

## **#2 Smart Controls, technologies & tariffs**

Colin Timmins (BEAMA)

## **#3 Home energy storage (heat and electricity)**

Gill Kelleher (SPECIFC) and Hanae Chauvaud de Rochefort (Association for Decentralised Energy)

## **#4 Overheating incl prevention & cooling**

Dave Bush (BBSA) and Phil Brown (GGF)

## **#5 Ventilation and Indoor Air Quality (IAQ)**

Nick Howlett (FETA) and Adrian Regueira-Lopez (BEAMA)

# #1 Domestic Hot Water, heating and 1-day hot water storage



**CoLeaders:**

**Jeff House**

**Steve Sutton**



HEATING & HOTWATER  
INDUSTRY COUNCIL

# SAP IF HEATING AND HOTWATER

9<sup>th</sup> July 2019

# SAPIF Group

<b>Baxi Heating UK</b>	<b>Jeff House</b>
<b>Worcester Bosch</b>	Ewan Sutherland
<b>Beama</b>	Adrian Regueira-Lopez
<b>Ideal Boilers</b>	Andrew Keyworth
<b>Enertek</b>	Paul Needley
<b>Recoup Energy</b>	Ian Steward
<b>Vaillant</b>	Martin Butcher, Ian Johnson
<b>Alpha Heating</b>	Darran Smith
<b>Thermaq</b>	Tony Staniforth
<b>Glen Dimplex</b>	Tim Altham
<b>Advance Appliances</b>	Geoff Egginton
<b>Mixergy</b>	Peter Armstrong
<b>Sav systems</b>	Beata Blachut, Silas Flytkjaer
<b>Ariston</b>	Derek Warren
<b>HWA</b>	Martyn Griffiths, Alan Clarke

# Technology Categories

Technology	Methodology in SAP 10.0	Category in PCDB
Hot Water Cylinders	Yes	No
	Comment: Separate sub-category for heat pump compatible cylinders may be required to reflect heat coil transfer rates and performance. Flexibility and addressable storage significant potential	
Thermal Stores and Combined Primary Storage Units	Yes	No
	Comment: Flexibility and addressable storage significant potential	

- DHW & Thermal Stores seen as important enabling technologies
- PCDB category desirable to enable performance differentiation and level playing field

# Category Templates

Technology Type	Eg. Hot water cylinder (direct / indirect / heat pump compatible etc.)
Methodology Included in SAP 10.0?	Yes / No
Product Category on PCDB?	Yes / No
Description of technology function including any limitations <i>(supplementary schematics or diagrams on separate sheets)</i>	Where not already established
Relevant BS / EN or other performance standards	
Smart Grid / ToU benefit to performance?	Yes/ No - description of operation
Modelling Proposals <i>(supplementary document if needed)</i>	Where not already established
Case Study or other supporting data? <i>(supplementary document if needed)</i>	

# Tech Interactions (Draft)

	Gas / Bio / H <sub>2</sub> boilers	Electric flow boilers	Hybrid	CHP / FC	Heat Pumps	Solar thermal	Solar PV	ToU / DSR
Hot water cylinder								
Thermal Store								
Battery Store								
Flue Gas Heat Recovery								
Waste Water Heat Recovery								
Point of use Water Heaters								

- Need to consider more complex system integration
- Multiple energy inputs
- Smart grid interface and modelling impact
- Depth / level of data needed for inclusion in SAP framework?

# USER Project Example

## AI Planning for Distributed Hot Water Heaters – System Integration

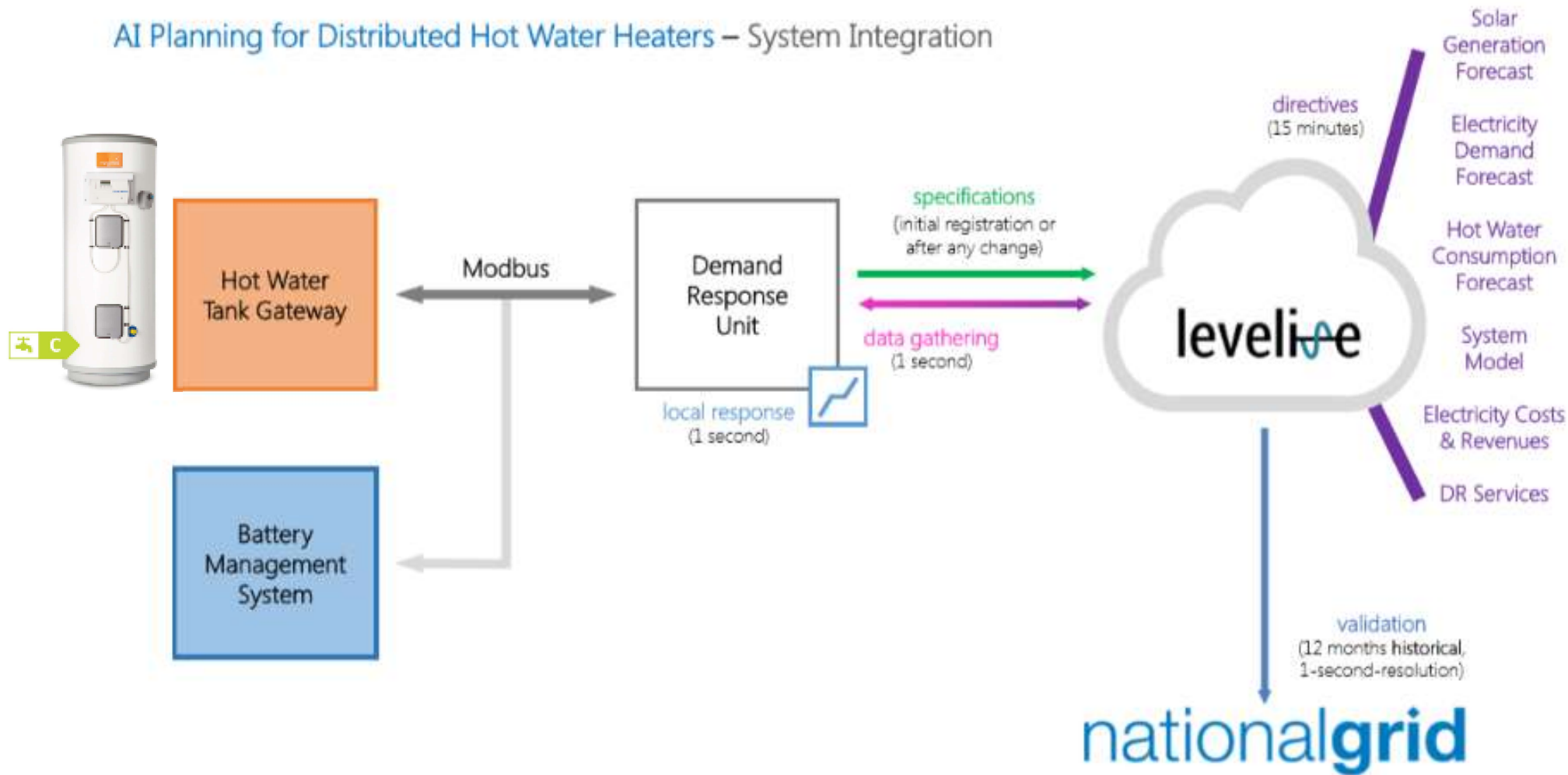



# DH & HIU's

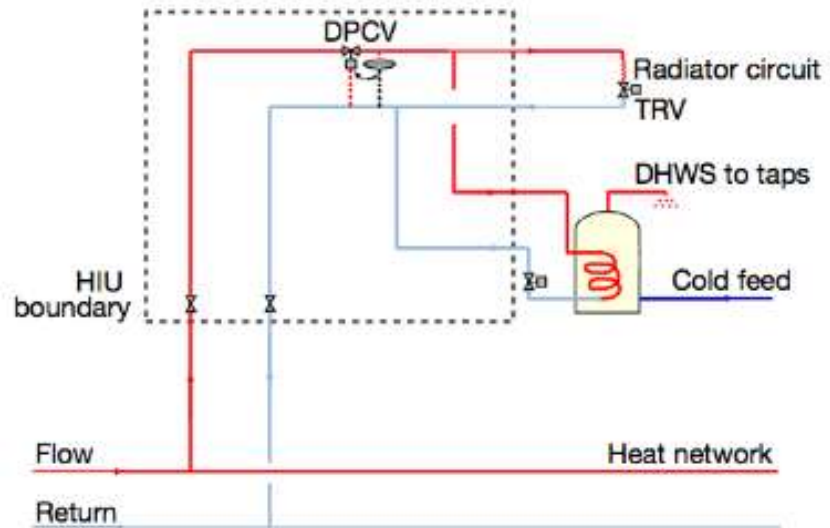
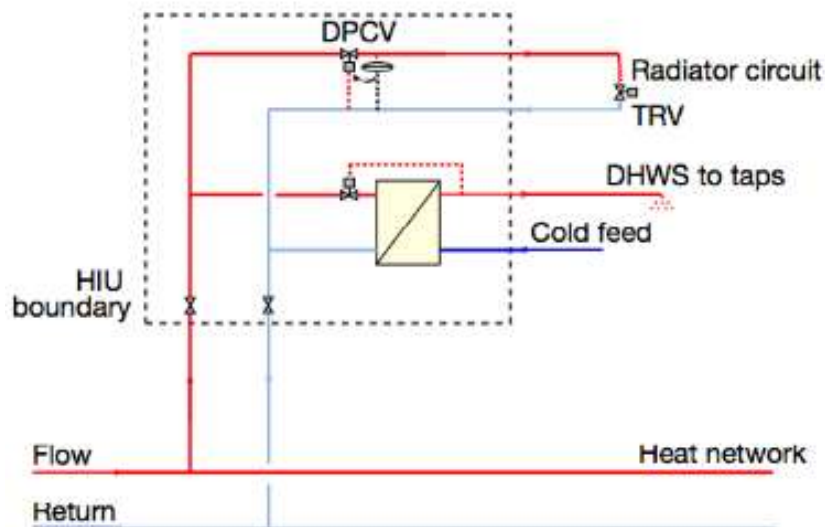

- No standardised / accepted test methodology for determining performance of HIU's in the UK
- Multiple types of execution (instantaneous / storage / local / central)
- Differing  $\Delta T$  values varying on a project by project basis – need to cater for a range
- PCDB again of value to correctly model application

# Next Steps

- Group meeting 16<sup>th</sup> July
- Discussion on overlaps and synergies between other working groups
- Complete category templates
- Draft report structure
- Set out milestones with group input

## #2 Smart Controls, technologies and tariffs



**Leader:**

**Colin Timmins**

## SAP 11 Working Group

### Smart controls, technologies and tariffs

Update – 9<sup>th</sup> July 2019

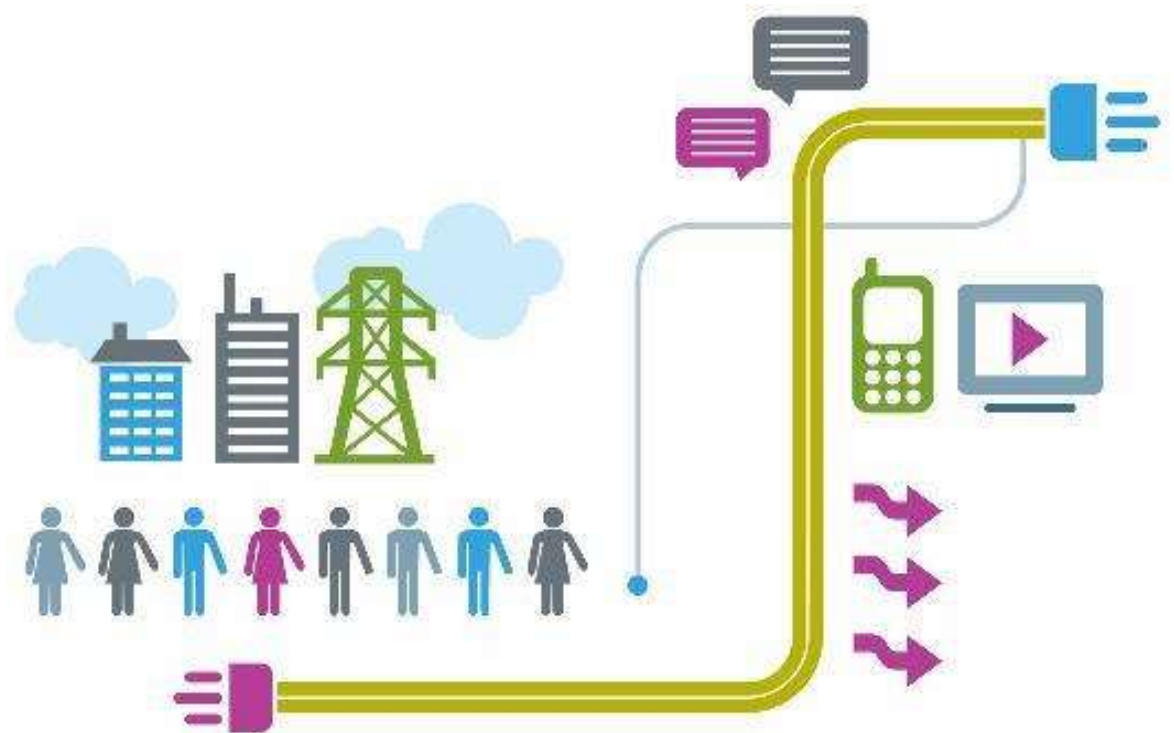

## March

BEAMA	Colin Timmins
BEIS	Philippa Hulme
Alpha	Darran Smith
Climote	Eamon Conway
Climote	Derek Roddy
Geo	Thom Wiffen
Glen Dimplex	Conor Mullaney
Glen Dimplex	Joe Hughes
HHIC	Steve Sutton
Ideal Boilers	Elizabeth Wilkinson
Ideal Boilers	Peter Millar
Nest	Alistair Chappelle
Octopus Energy	David Sykes
Resideo	Rob Whitney
Rettig	David Pittila
Schneider Electric	Dave Kempster
Schneider Electric	Ryan Howes
Somfy	Julian Cyprien
SSE	Phillip Kettless
Tech UK	Teodora Kaneva
University of Salford	Richard Fitton
Vaillant	Andrew Ireland/Mark Barson
Worcester Bosch	Chris Watling

## July

BEAMA	Colin Timmins
BEIS	Philippa Hulme
Alpha	Darran Smith
Climote	Eamon Conway
Climote	Derek Roddy
Danfoss	Andrew Axtell
Geo	Thom Wiffen
Glen Dimplex	Conor Mullaney
Glen Dimplex	Joe Hughes
HHIC	Steve Sutton
Ideal Boilers	Elizabeth Wilkinson
Ideal Boilers	Peter Millar
Nest	Alistair Chappelle
Octopus Energy	David Sykes
Resideo	Rob Whitney
Rettig	David Pittila
Schneider Electric	Dave Kempster
Schneider Electric	Ryan Howes
Somfy	Julian Cyprien
Somfy	Steven Montgomery
SSE	Phillip Kettless
Tech UK	Teodora Kaneva
University of Salford	Richard Fitton
Vaillant	Andrew Ireland
Worcester Bosch	Chris Watling
Worcester Bosch	Stefan Kluepfel
Worcester Bosch	Andrew Robinson

- May be confidentiality issues in getting an evidence base for new technologies.
  - The level of substantiation required for technologies to be accepted into SAP needs to be known.
  - SAP currently looks at how smart controls could potentially shorten the standard heating periods, but the actual premise of a smart control might be to ensure the heating profile matches the occupants needs as closely as possible.
-

	Categories of control/optimisation/visualisation	Technologies included	Impact on standard SAP profile/assumptions
1	Automatically change duration of heating	Occupancy detection, remote control (automatic), learning of occupancy patterns	Reduce time where people leave the dwelling during the schedule, or don't return during schedule.
2	Manually change duration of heating from outside the dwelling	Remote control (manual app)	Occupants can defer heating operation when not coming home
3	Apply setback temperatures for part of the 'on' period	Programmable thermostat, occupancy detection, remote control (automatic), remote control (manual)	Reduce internal temperature for part of occupancy
4	Automatically change duration of heating for individual rooms	Occupancy detection + room temperature control	Reduce proportion of house heated leading to lower average temperature
5	Automatically apply setback temperatures for individual rooms while heating is on	Occupancy detection + room temperature control	Reduce average temperature
6	Set time and temperature profiles for individual rooms based on non-standard profiles, e.g. home working	Room temperature control + central program control	Change profiles for occupancies
7	Change hot water storage by learning usage patterns	Learning of usage patterns	Reduces overall hot water production/storage based on expected demand and price based signals or renewable availability
8	Change hot water storage from occupancy detection	Occupancy detection	Limit hot water storage after multiple days of no occupancy
9	Change the amount of energy used at particular times based on carbon intensity (current)	Knowledge of current carbon intensity of energy supply	Reduce carbon intensity, possibility at the expense of greater energy use, based on flexible tariff/grid carbon API

	Categories of control/optimisation/visualisation	Technologies included	Impact on standard SAP profile/assumptions
10	Change the amount of energy used at particular times based on carbon intensity (current and future)	Knowledge of current and future carbon intensity of energy supply. Knowledge of future availability of renewable energy sources.	Reduce carbon intensity, possibility at the expense of greater energy use, based on flexible tariff/grid carbon API + predicted use of renewables
11	Change operating time based on carbon intensity (current)	Knowledge of current carbon intensity of energy supply	Defer operation based on flexible tariff/grid API
12	Change operating time based on carbon intensity (current and future)	Knowledge of current and future carbon intensity of energy supply. Knowledge of future availability of renewable energy sources. Learnt heating and hot water requirements.	Defer operation based on flexible tariff/grid API + learnt heating/hot water needs + potential thermal storage + predicted use of renewables
13	Change the amount of energy used at particular times based on energy cost (current)	Knowledge of current unit price of energy supply	Reduce energy used, based on flexible tariff cost
14	Change the amount of energy used at particular times based on energy cost (current and future)	Knowledge of current and future unit price of energy supply. Knowledge of future availability of renewable energy sources. Learnt heating and hot water requirements.	Reduce energy used, based on flexible tariff/ + predicted use of renewables + learnt heating/hot water needs
15	Change operating time based on energy cost (current)	Knowledge of current unit price of energy supply	Defer operation based on flexible tariff



	Categories of control/optimisation/visualisation	Technologies included	Impact on standard SAP profile/assumptions
16	Change operating time based on energy cost (current and future)	Knowledge of current and future unit price of energy supply. Knowledge of future availability of renewable energy sources. Learnt heating and hot water requirements.	Defer operation based on felexible tariff + learnt heating/hot water needs + potential thermal storage + renewables
17	Controls to integrate energy use with thermal storage to optimise carbon intensity of energy used in the building		Provides more flexibility for offsetting heating/hot water load (might increase energy use but lower carbon and cost)
18	Controls to integrate energy use with electrical storage to optimise carbon intensity of energy used in the building		Provides more flexibility for offsetting heating/hot water load + MVHR + appliances + EV (might increase energy use but lower carbon and cost)
19	Financial prompts for users to alter behaviour/settings		Tariff or control signals for customers to move operation of appliance to times of lower carbon intensity
20	Control/device prompts users to alter behaviour/settings		Reduce time or temperature of operation or energy use through automatic prompts indicating where usage is excessive or behaviour could be more environmentally friendly
21	Automatic reduction of settings		Automatically reduces time or temperature settings which users can reset if needed/noticed
22	Maintenance prompts from control/device		Informing user or installer of sub-optimal performance of appliances or changes in physical conditions or performance of building.

- Presentation on evidence available for technologies covered by this group (from group members)
  - Discussion on suitability of evidence provided
  - Identification of gaps
-

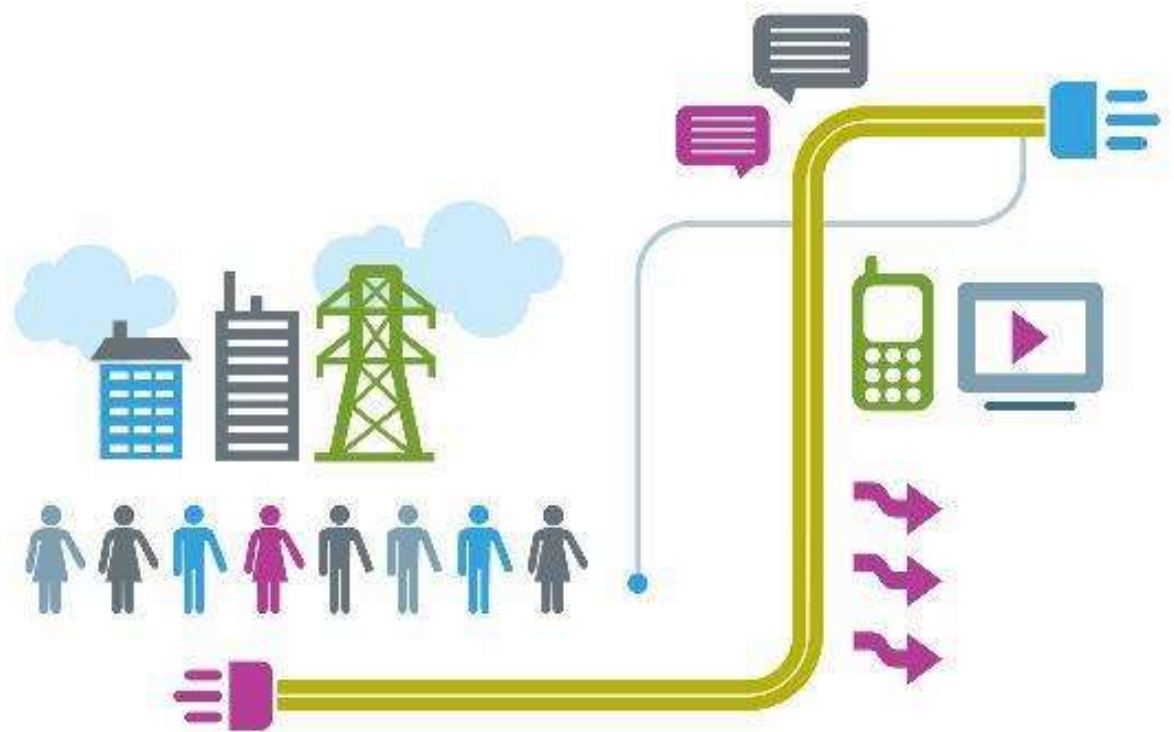

# #3 Home energy storage (heat and electricity)



**CoLeaders:**

**Gill Kelleher**

**Hanaé Chauvaud de Rochefort**



**1** Overview

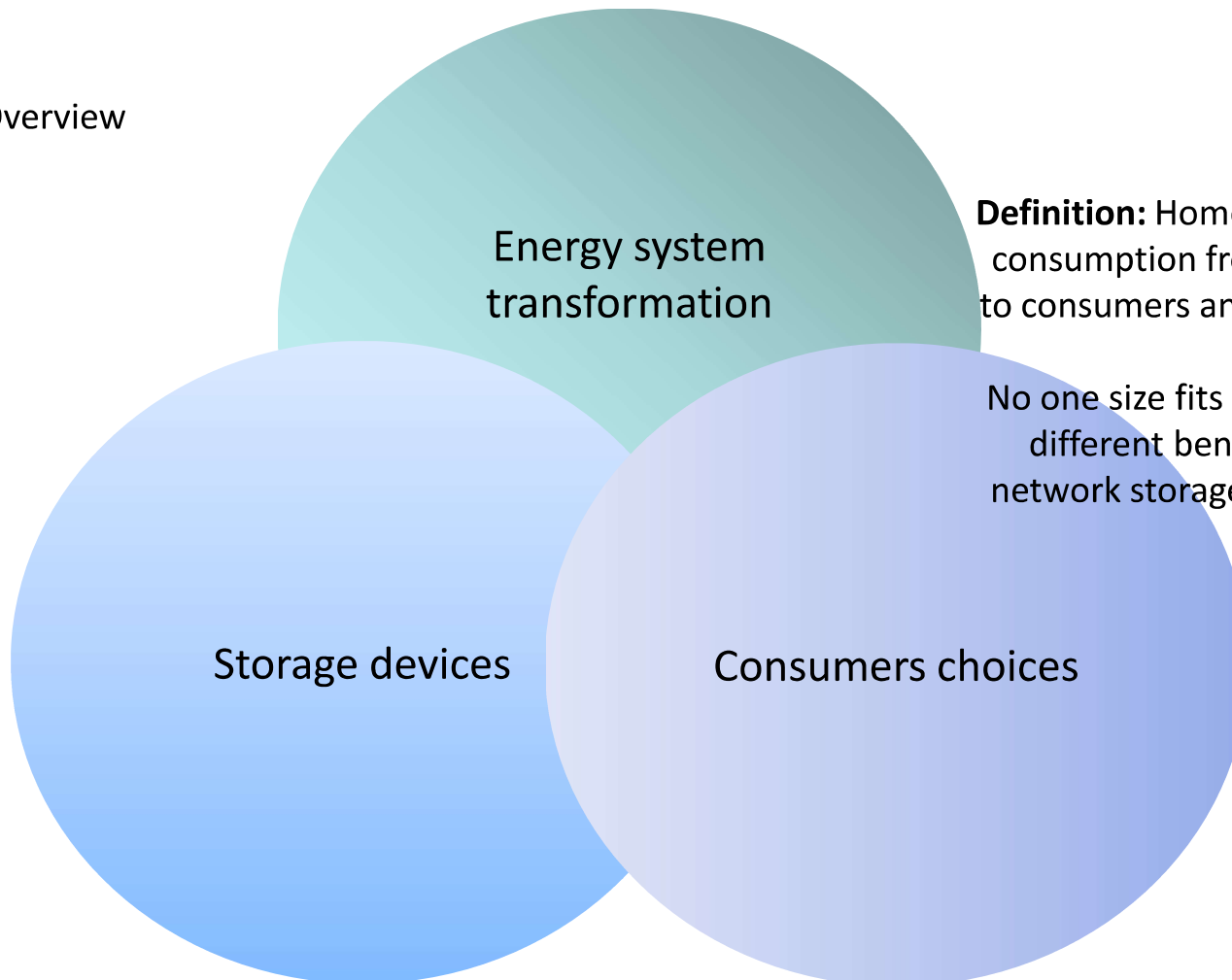

**Definition:** Home Energy Storage differs times of consumption from production, optimizes costs to consumers and contributes to climate change mitigation.

No one size fits all - different technologies offer different benefits (eg., flexibility, in home, network storage, community heat systems etc)



## 2 Technology list

Summary of the working group session:

- List of Technologies SAP11 – no one size fits all
- Future Modelling Criteria for SAP11
- Future Homes Standard: Technologies to be modelled



## 3 Modelling gaps and success factors

- We understand that a key barrier to storage technologies is that they currently cannot be modelled with SAP. Critical success factors:
  - 1) figure out possible ways to calculate a SAP rating and announce to the home energy storage supply chain what they can expect re-Building Regulations compliance, and
  - 2) suggest that success factors of such task is finding the finance/reliability benefits to users alongside the environmental benefit to the wider ecosystem.

# SAP Industrial Forum: Home Energy Storage

---

## 4

### Feedback on the BEIS technology list

- The FHS won't be a case of one-size-fits-all, other options than purely heat pumps and hybrid heat pump systems should also be modelled – where is energy storage? Where is flexibility?
- Arbitrages in terms of the user's energy demand AND the energy source availability at this time (renewable or cost incentive of running a CHPs vs simple boiler)
- The work should tie in with the electricity grid charging reviews and Time of Use (ToU) tariff reforms to consider these in modelling alongside an appropriate winter heat demand profile – without considering these reviews the model will limit innovation in energy storage and create impractical suggestions
- Consider technologies cost curves – where policy support helps grow the supply chain there should be cost reductions/economies of scale to make a viable solution on the long term



# #4 Overheating including prevention and cooling



## CoLeaders:

**David Bush**

**Phil Brown**

SAPIF:

# Working Group #4 Overheating

David Bush – British Blind and Shutter Association  
Phil Brown – Glass and Glazing Federation

# Working Group Members



Phil Brown

## New Members:



Joe Miles and  
Kate Brown



Dave Bush and  
Zoe De Grussa



Barny Evans



Matthew Hurd



Silvio Junges



Neil Freshwater



Andrew Mitchell



Jodie Evans and  
Owen Gallagher



Steven Montgomery



## Progress this Quarter...

- One Meeting between members.
- Networked to recruit **5 New Members** to fill knowledge gaps.
- Group members have started uploading evidence documents to the group Dropbox. This information is also being disseminated into simplified 'Evidence Documents' for each technology area.
- Discussions have identified further areas within the group where we do not have expertise.

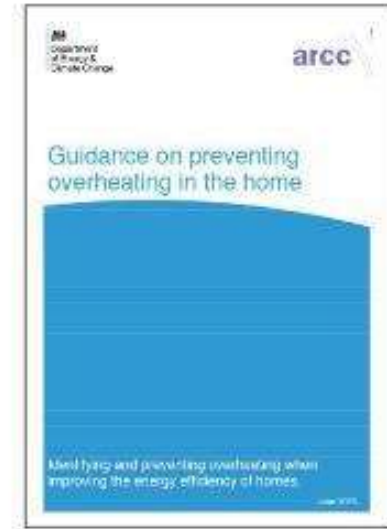
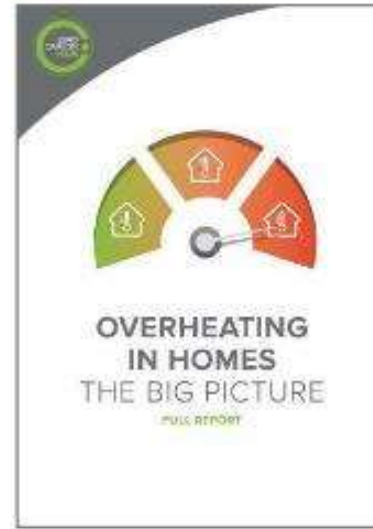
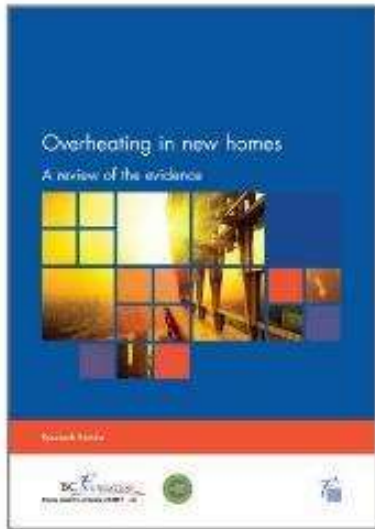

Well documented that **overheating** is a problem!

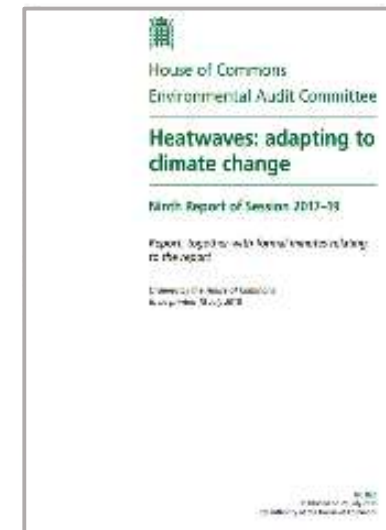
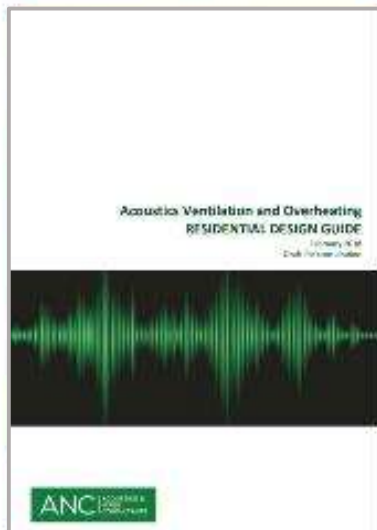

# Reduced into a 'Working' Overheating Context Document

- Summary of SAP Appendix P
- Principles of Overheating
  - External Heat Gains
  - Internal Heat Gains
  - Poor Ventilation
- Factors that Increase Overheating
  - Site Context
  - UHI
  - Orientation
  - Building Design
  - Thermal Mass
  - Service Design (e.g. Hot Water)
  - Restricted Ventilation (Acoustics / Security and Air Pollution)
  - Cumulative Effects
  - Human Behaviour (To be Added)
- Consequences of Overheating
  - Increase in Active Cooling / Cooling Energy Use
  - Negative Impact on HW&C
  - Negative Impact on Productivity (Home Workers/Sleep Deprivation) (To be Added)



Aim

Improved Assessment of  
Overheating

Application

Technologies in SAP

Affected by...

Occupant  
Behaviour

Control

Building  
Modelling

Building  
Design

Air Quality  
and  
Acoustics

## New Technologies

### Shading

- New Fabrics with improved Gtot.
- Automated and Motorised Control Systems

### Glazing

- Suspended Particle Device
- Thermochromic
- Polymer Dispersed Liquid Crystal
- Electrochromic

### Thermal Mass

- TBC

### Ventilation

- Mechanical Ventilation Heat Recovery (MVHR)
- Accurate Natural Ventilation
- Passive Cooling

### Energy Generation

- Building-integrated photovoltaics

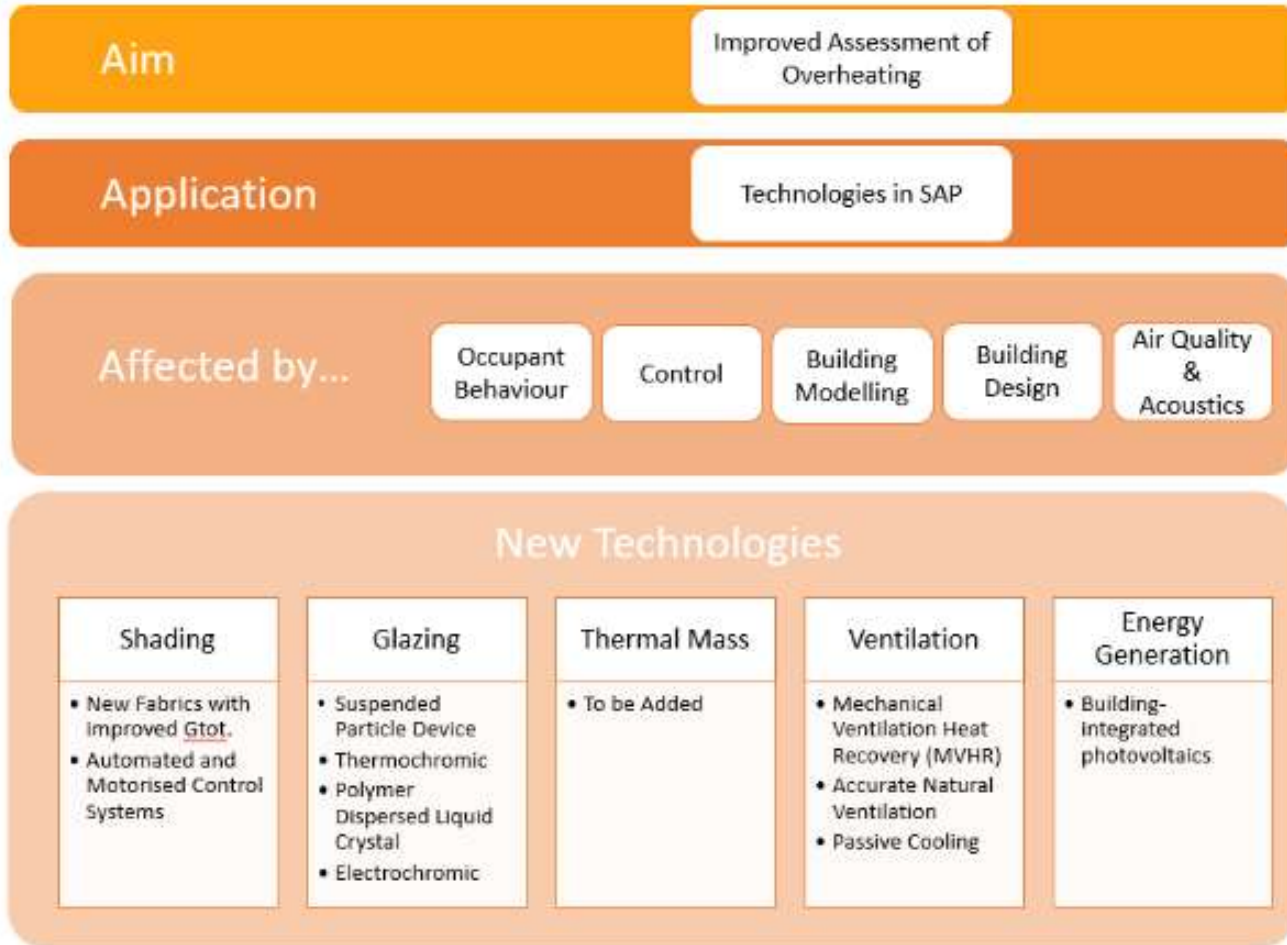

Each Technology Area will **produce an Overheating 'Evidence Document'** considering the elements that may **affect them and how they are applied in SAP.**

They will also **review how the technologies effect each other.**



# Compiling the Evidence Document Example “Shading”

- Overheating ‘Shading’ Database Produced

- Sorting Literature with Shading Relevance for Evidence
- Simplified Literature to Title, Author, Summary and Shading Specific Quotes and Links to Resources for other Members.
- 62 Documents Added

Database Updated		21.09.19		Instructions			
				Please scroll left to the top of each column to filter by Title, Author, Year or Location			
Title/Key	Author	Summary	Keywords	Year	Location	Link	
Overheating in the workplace	Wheeler, M. & Newell, C. (2018)	The authors discuss the health and safety implications of overheating in the workplace and recommend an approach to assess the risk of overheating in the workplace. The authors recommend that the risk of overheating in the workplace should be assessed using a risk assessment approach. The authors also recommend that the risk of overheating in the workplace should be assessed using a risk assessment approach.	Overheating, Workplace, Health and Safety	2018	UK	<a href="#">https://www.gov.uk/government/uploads/system/uploads/attachment_data/file/369441/Overheating_in_the_workplace.pdf</a>	
Overheating in the workplace: A review of the literature	Wheeler, M. & Newell, C. (2018)	This paper considers the methodological approaches and findings of a systematic review of the literature on overheating in the workplace. The authors recommend that the risk of overheating in the workplace should be assessed using a risk assessment approach. The authors also recommend that the risk of overheating in the workplace should be assessed using a risk assessment approach.	Overheating, Workplace, Health and Safety	2018	UK	<a href="#">https://www.gov.uk/government/uploads/system/uploads/attachment_data/file/369441/Overheating_in_the_workplace.pdf</a>	
Overheating in the workplace: A review of the literature	Wheeler, M. & Newell, C. (2018)	This paper considers the methodological approaches and findings of a systematic review of the literature on overheating in the workplace. The authors recommend that the risk of overheating in the workplace should be assessed using a risk assessment approach. The authors also recommend that the risk of overheating in the workplace should be assessed using a risk assessment approach.	Overheating, Workplace, Health and Safety	2018	UK	<a href="#">https://www.gov.uk/government/uploads/system/uploads/attachment_data/file/369441/Overheating_in_the_workplace.pdf</a>	
Overheating in the workplace: A review of the literature	Wheeler, M. & Newell, C. (2018)	This paper considers the methodological approaches and findings of a systematic review of the literature on overheating in the workplace. The authors recommend that the risk of overheating in the workplace should be assessed using a risk assessment approach. The authors also recommend that the risk of overheating in the workplace should be assessed using a risk assessment approach.	Overheating, Workplace, Health and Safety	2018	UK	<a href="#">https://www.gov.uk/government/uploads/system/uploads/attachment_data/file/369441/Overheating_in_the_workplace.pdf</a>	
Overheating in the workplace: A review of the literature	Wheeler, M. & Newell, C. (2018)	This paper considers the methodological approaches and findings of a systematic review of the literature on overheating in the workplace. The authors recommend that the risk of overheating in the workplace should be assessed using a risk assessment approach. The authors also recommend that the risk of overheating in the workplace should be assessed using a risk assessment approach.	Overheating, Workplace, Health and Safety	2018	UK	<a href="#">https://www.gov.uk/government/uploads/system/uploads/attachment_data/file/369441/Overheating_in_the_workplace.pdf</a>	

# Evidence Compiled Example “Shading”

- Overheating ‘Shading’ Database Produced

- Sorting Literature with Shading Relevance for Evidence
- Simplified Literature to Title, Author, Summary and Shading Specific Quotes and Links to Resources for other Members.
- 62 Documents Added

- Overheating ‘Shading’ Database used to inform Shading Evidence Document.



**SAPIF Overheating Working Group**  
**Solar Shading Technologies to prevent Overheating**

**1. How it works?**

Solar Shading devices reject heat gain in summer when extended (closed) and when retracted (opened) allow more heat gains to enter the building, which can be beneficial in winter months. Simultaneously as shading is extended the thermal retention properties of the glazing are also improved and when retracted are reduced.

This dynamic ability allows shading to be both beneficial in summer when heat needs to prevent from entering our buildings and beneficially in winter when solar gains can be beneficial in winter. Similarly retracting blinds in summer at night can improve natural ventilation and reduce the thermal retention properties of the building.

A summary of how dynamic solar shading can be used effectively throughout the year is presented in Figure 1.



Figure 1. Recommended use of dynamic solar shading by time of day and season.

**2. Solar Shading and Heat Rejection Performance**

Shading products that are fit to a window have varying properties that impact the effectiveness of a window system at rejecting solar gain. This is summarised into one value known as the  $g_{sh}$ . This is the measure of the total energy transmittance of the glazing in combination with the shading when exposed to solar radiation. The value of  $g_{sh}$  is between 0 and 1, where 0 equates to no radiation being transmitted into the room and 1 means all radiation (100%) is transmitted. The calculation methodology is given

# Gaps in Working Group

- Ventilation and Acoustics Solutions  
(e.g. External Façade Panelling combined with Ventilation (See Image Right))
- Ventilation and Air Quality
- Building Simulation Methodologies
- Impact of Controls / Automation
- Application of Technologies in SAP
- Case Studies of buildings where all or a combination of outlined technologies have been considered.

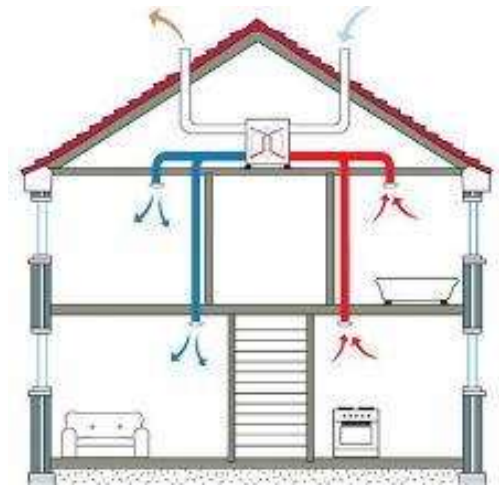

## CONCEPT - SMART READINESS INDICATOR – SRI



### EXPECTED ADVANTAGES

- optimised energy use as a function of (local) production
- optimised local (green) energy storage
- automatic diagnosis and maintenance prediction
- improved comfort for residents via automation

# Questions from Working Group

- Has it been confirmed whether a Dynamic or Static Simulation Method will be used to improve the SAP Overheating Assessment? For example TM59?
- Can we set up a formal meetings with the Controls and Ventilation Groups to fill gaps in knowledge?
- How do we deal with new products / technologies for which International / European standards are only now emerging and playing 'catch up'?
- For case studies in real buildings in the UK, what is considered a reasonable amount of evidence (compared with 'theoretical' modelling)?
- How do we address generic vs proprietary product / technologies (particularly where the proprietary product / technology can provide better performance)?

# Timeline of Work

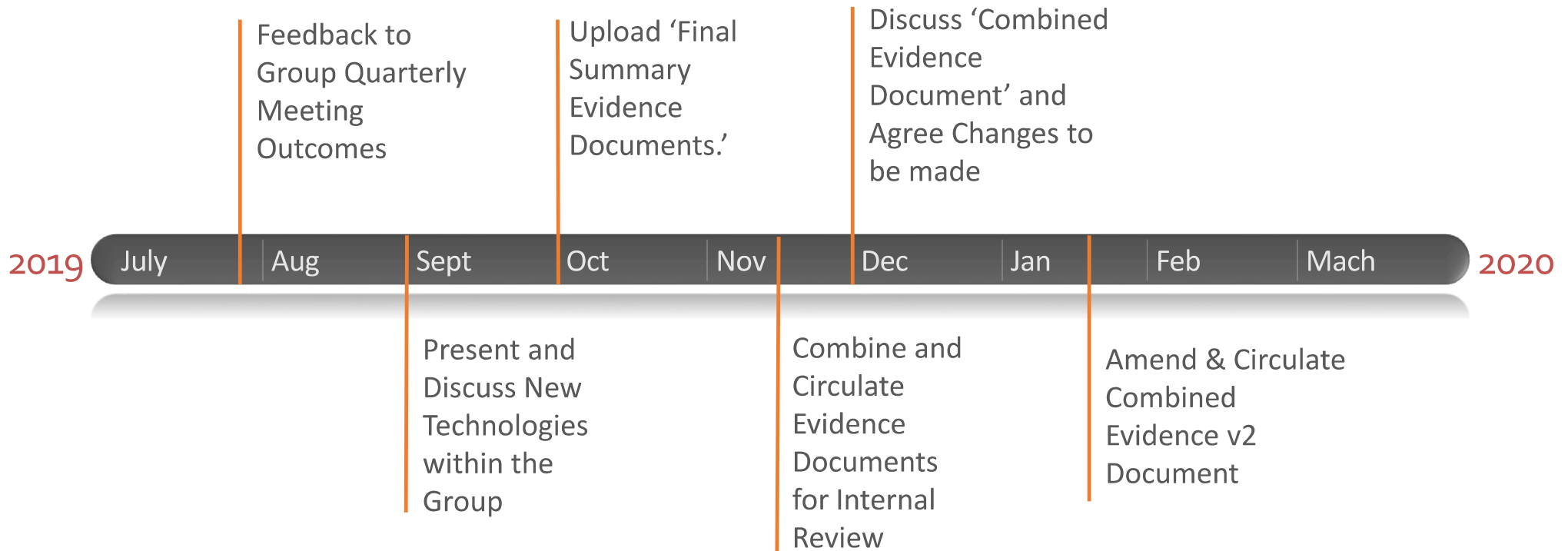

Thank you for Listening

# #5 Ventilation and Indoor Air Quality (IAQ)



## CoLeaders:

**Adrian Regueira-Lopez**

**Nick Howlett**



IAQ and Ventilation WG

SAPIF

9<sup>th</sup> of July 2019 update







IAQ and Ventilation WG 5

SAPIF

9<sup>th</sup> of July 2019 update



Objectives:

To establish technologies/systems coming in the mid 2020's

To propose some modelling criteria for the performance (and compliance) of the technologies identified.

To work with Government and the SAP contractor to develop this further, if necessary.



Scope: New control systems that directly address air quality e.g. VOC's, CO, CO<sup>2</sup>, NOx and Humidity.

Do not conflict with Part F.



- Members of WG 5 as at April 2019
- Aereco
- Airflow
- BEAMA
- Envirovent
- Residential Ventilation Association (RVA part of FETA)
- Nuaire
- Titon
- West Energy
- Zehnder



WG 5 Meetings

February 2019

April 2019

Next meeting due 23<sup>rd</sup> of July 2019.

Important note: Trade bodies have meetings in the week after this meeting. This matter is on the Agenda for both meetings.



Update from the April meeting of WG5

Unapproved notes of the meeting.

The meeting discussed and concluded that it is not possible for Industry to propose innovative SAP technologies and divorce this from Ventilation and Indoor Air Quality as set out.

The group believes that Indoor Air Quality (IAQ) should not be subordinated by Energy Efficiency. It is very difficult, if not impossible, to apply controls that attract any reward in the NCM, where ventilation rates are set at minimums in ADF. There should be flexibility in providing energy efficient ventilation rates between the minimum ventilation rates and increased rates as required, based on occupancy levels. This should be recognised in future calculation methods.

Action: To be fed back to the SAPIF Groups Chair's forum for consideration.

Industry is considering whether the proposed methodology for assessing innovative technology products maybe likely to further restrict developments rather than encourage it.

Industry will discuss whether it is willing to consider Industry standards for controls where none exist at present.





Since the last meeting:

ADF BRAC Subgroups for ADF and Overheating have met

NICE have published their interim report on IAQ for England.



# Summary



## The overall objectives:

1. Initial awareness
2. Publicise each WGs work + opportunity to contribute.
3. WG overlaps and interfaces with other WGs
4. End Q1 2020 and Part L is out of scope

## Key aspects:

- For SAP 11
- Complete end Q1 2020
- New technologies - available in mid-2020s onwards
- Performance Modelling criteria and how judge compliance



# SAPIF WGs' Data Store



- Shared SAPIF folder with subfolders for each working group
- You'll receive a link in an email from John Henderson looking something like this:

Here's the folder that Henderson, John shared with you.

This link only works for the direct recipients of this message.

 SAPIF document repository

[Open](#)

 Microsoft OneDrive

Microsoft respects your privacy. To learn more, please read our [Privacy Statement](#).  
Microsoft Corporation, One Microsoft Way, Redmond, WA 98052

# SAPIF WGs' Data Store



- Access is limited to named recipients of the link (SAPIF members)
- Simplest way to access the folder is to click on this link each time
- If you are asked for a password, that is your own email password – not one set by BRE / RDL / BEIS (so don't ask us what it is!)
- Should all 'just work', but let us know if any teething problems that you think are not fixable at your end

# The next steps



What would you like .....

What is the timeline .....

What are the outputs .....

Future SAPIF meeting(s) .... Objectives .....

October	Open to all	“How are we doing?”
January 2020	Open to all	“Last chance before handover”
March 2020	Leaders / CoLeaders only	Presentation of findings

**thank**you



**www.robust**details.com