

A series of experiments to assess the effect of fire on a selection of electrical cable supports and fixings

By Ciara Holland, Martin Shipp and David Crowder



Introduction

BRE Global carries out fire investigation activities on behalf of the Department for Communities and Local Government (DCLG). An important element of this contract with DCLG is to ensure that findings from fire investigations are made available to the fire community, and other stakeholders. In addition to the continued investigative work carried out by BRE Global, the latest contract includes an element of experimental work to allow further analysis of issues arising from investigations of incidents.

Background

There have recently been several recommendations made to UK Government, by HM Coroners and others, regarding falling cables in burning buildings. These recommendations have been made after several incidents where fire-fighters have been trapped by falling cables in burning buildings and this has, in some cases, contributed to fire-fighter fatalities.

BRE Global is aware of three incidents where there have been fire-fighter fatalities as a result of being trapped by falling cables in a burning building. These are:

- Harrow Court, Hertfordshire, 2nd February 2005
 - Two fire-fighters and a resident died in a fire in a high-rise block of flats. The fire-fighters were trapped by fallen fire alarm cables prior to an event of abnormal rapid fire development.
 - Following an inquest in March 2007, HM Coroner Mr Edward Thomas issued several recommendations through a Rule 43 letter [1, 2] including a recommendation to social housing providers regarding the support of fire alarm cables which should conform (as a minimum) to BS 5839 – Part 1 : 2002; clause 26.2 (f:) [3].
- Atherstone-on-Stour, Warwickshire, 2nd November 2007
 - Four fire-fighters died in a large, highly-insulated warehouse fire.
 - It was noted from witness statements that fire-fighters were being caught up in fallen cables during the incident. It is unclear whether the four fatalities were trapped by cables.
 - Warwickshire Fire and Rescue Service issued an Operational Bulletin in March 2012 (OB 12/04) regarding “Hanging Cable Hazards from Surface Mounted Conduit and Trunking” as a result of experimental work carried out by BRE Global for the Fire Service [4]. This work confirmed that plastic conduit or trunking surface mounted on ceilings and walls may fail at relatively low temperatures (150°C).



- Shirley Towers, Hampshire, 6th April 2010
 - Two fire-fighters died while fighting a fire in a high-rise block of flats after being trapped by fallen cables prior to an event of abnormal rapid fire development.
 - Following an inquest in February 2013, HM Coroner Mr K Wiseman issued recommendations in several Rule 43 letters [1, 5] including reiterating the recommendations made by HM Coroner Mr Thomas after the Harrow Court inquest. Mr Wiseman made a further recommendation to have "... Building Regulations amended to ensure ALL [sic] cables, not just fire alarm cables, are supported by fire-resistant cable supports". Mr Wiseman recommended an "amendment to BS 7671 (2008)..." to achieve this [6].

Objectives

The overall aim of this project was to assess the ability of a selection of commercially available cable supports for electrical installations to maintain their integrity and hold electrical cabling in place when exposed to temperatures typically encountered in compartment fires. A second series of experiments was carried out to assess the performance of a range of commercially available fixings for cable supports in concrete substrates when exposed to elevated temperatures. The findings of the experiments are intended to inform DCLG Building Regulations and Standards Division about the installation of cables in buildings.

This experimental work was not intended as a comprehensive testing programme of individual products but rather as a "proof of concept" and to demonstrate a possible simple solution to the issues which have been raised.

Methodology

Cable supports experiments

Experimental rig

An experimental rig was designed and constructed using the ISO 9705 fire test room [7] (ISO room) of dimensions 3.6 m x 2.4 m x 2.4 m, extended with a timber-frame and plasterboard (single layer 12.5 mm Type F [8]) lined corridor of dimensions 3.5 m x 1.5 m x 2.4 m attached to the front of the ISO room (see Figure 1 and Figure 2). The walls, floor and ceiling of the ISO room were lined with two layers of 12.5 mm Type F plasterboard. The ISO room used for the experiments is a portable room on wheels which was raised approximately 300 mm from the ground; hence the corridor was not in line with the top of the ISO room (see figure 2).

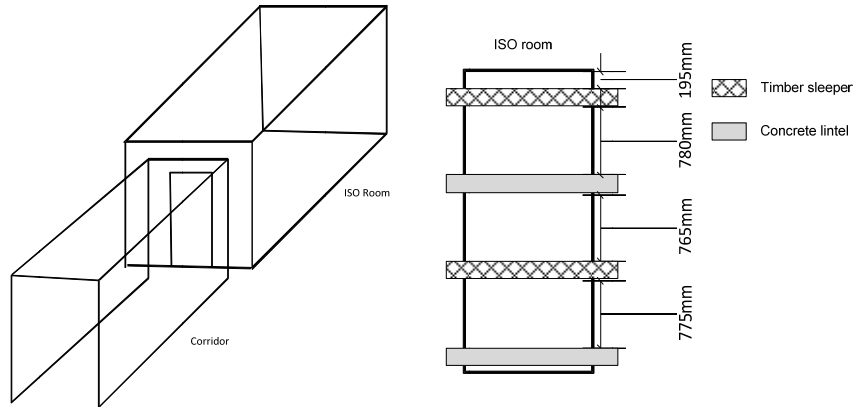

Figure 1 - Schematic of experimental rig, left, and plan view of corridor, right, indicating the layout of the timber sleepers and lintels to which the cable supports were fixed



Figure 2 – Images of experimental rig

Four sets of five cables, supported with a selection of cable supports, were installed horizontally across the width of the corridor. The cables and supports were fixed to different structure types; timber sleepers and concrete lintels, which were placed alternately, approximately one metre apart along the corridor (see

The timber sleepers and concrete lintels were approximately 220 millimetres wide. For the purpose of this article, these sleepers and lintels will be referred to as lintels. Typical layout of the installation of the cable supports can be seen in Figure 2. For ease of reporting, the lintels have been numbered from 1 to 4, where Lintel 1 is closest to the ISO room and hence closest to the fire.



Figure 3 - Close up of cable set fixed to a timber sleeper with the selection of cable supports prior to an experiment

Cables and cable supports

Standard 1.5mm flat twin and earth PVC sheathed cable was used for all experiments. Within each set of cables, a length of conduit was fixed to the lintel. The conduits were 20mm heavy gauge PVC, cut to size to fit in the corridor.

Five types of cable support, one plastic and four metal, were selected for these experiments and represent commercially available “fit for purpose” cable supports. Details of these cable supports are provided in Table 1. The cable supports were fitted approximately 300 mm apart along the cable length with five supports of each type per lintel.

NOTE. For the purposes of this report, we refer to the metal cable supports as “supports” and the plastic cable clips as “clips”. “Fixings” are the means of securing the cable supports or clips into the structure.

With the exception of Clip 5, all the supports were fixed to the timber lintels using zinc-plated hardened steel 7 x 1¼ inch twinthread wood screws which were screwed directly into the timber. Clip 5 was fixed using its own pin. The same fixings were used for all the supports, including Clip 5, in the concrete lintels although for these lintels the screws were fixed into standard plastic wall plugs.

Table 1 – Cable supports used in the experiments

Number	Detail
Support 1	Zinc plated saddle support. These supports are used in the automotive industry for fixing cables.
Support 2	Galvanised steel spacer bar saddle for use with conduit.
Support 3	Passivated stainless steel cable support with fold over fastening tabs for use with 2 core 1.5 mm fire alarm cables. The support meets the requirements of BS 5839-1 [3].
Support 4	Double cable saddle support for 2 core 1.5 mm fire alarm cable. This support was made of copper and coated with a polymeric coating. The support is understood to comply with BS 476 Part 6 [9], BS 476 Part 7 [10], UL 94 [11] and meets the cable support requirements of BS 5839-1:2002 [3].
Clip 5	Moulded plastic flat 1.5 mm clip with pre-fitted zinc-plated carbon steel pin.



For the first experiment the cable supports were fitted by the contractor who erected the rig. The cable supports for the second experiment were fitted by BRE Global staff using the same plastic wall plugs as for the first experiment since they remained undamaged.

Instrumentation

The experimental rig was fitted with a range of Type K thermocouples used to measure temperature within the rig. In total, 21 thermocouples were used for each of the experiments. Each lintel had a 1.5 mm steel sheathed thermocouple either side in the centre of the rig to measure, approximately, the temperatures which the supports were being exposed to during the experiments (see Figure 4). A further two 1.5 mm diameter thermocouples were placed just below the ceiling, close to each wall, half way along the corridor (see Figure 4), to monitor any variations in temperature across the width of the corridor. There were also two vertical arrays of thermocouples; one located right of centre in the ISO room approximately one metre from the crib and one midway along the corridor. The thermocouples in the vertical array in the ISO room were spaced at approximately 0.5 m intervals from the ceiling and contained six thermocouples. The vertical array in the corridor had similar spacing but contained only five thermocouples. Welded tip Type K thermocouples were used for the vertical arrays of thermocouples in the ISO room and in the corridor.

The performance of the supports was monitored during the experiments with visual observations and using video equipment with a total of four cameras.

Experimental method

Two experiments (designated Experiment 1 and Experiment 2) were carried out, each using a wood crib fire. The fires were positioned in the centre of the ISO room part of the rig to allow the smoke and hot gases from the fire to flow into the corridor. Ignition of the cribs was achieved by introducing a naked flame to fibreboard strips soaked in methanol.

The crib for the first experiment was capable of generating a 0.7 megawatt (MW) fire and the crib for the second experiment was capable of generating a 1.3 MW fire; however, the heat release rate of the fires was not measured.

The experiments were run until the peak temperature was observed and the fire had started to cool down due to a lack of available fuel.

A liquid pool fire would have produced less dense smoke than the wooden crib fires and would have afforded better visibility of the cable supports during the experiments. However, wooden crib fires were considered the better option for this series of experiments because the wooden crib fires afford a more gradual temperature rise and follow a more “typical” fire growth curve to simulate a typical compartment fire. This “typical” fire growth curve would not have been achieved with a liquid pool fire.

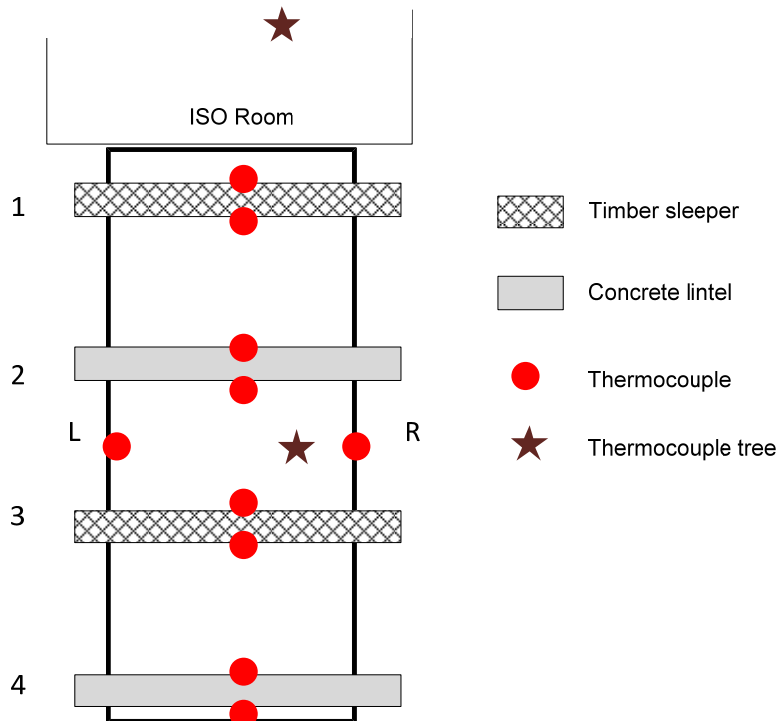

Figure 4 – Locations of thermocouples in relation to lintels in the corridor of the experimental rig

Fixings experiments

A series of bench-scale experiments was carried out using a range of commercially available fixings for cable supports for use in concrete substrates; these fixings included plastic plugs and self-tapping screws.

Fixings and experimental setup

The fixings were installed into standard aerated 3.6N concrete blocks (see Figure 5) of dimensions 440mm by 215mm by 100mm deep. Each block was placed horizontally into an oven on top of two other concrete blocks (placed vertically) as supports to allow for the suspension of weights from the fixings.

Steel bolts were used as weights, attached to the fixings using steel wire. Each weight was approximately 85 g i.e. a single fixing, based on the weight of two 0.3m lengths of twin and earth cable (~340 g) and having two cable supports on such a length with two fixings per support.



Figure 5 – Fixings installed in concrete block with weights attached

Table 2 provides details of the fixings which were used for these experiments. BRE Global notes that most commercially available fixings for masonry or concrete substrates are medium to heavy duty fixings with a minimum diameter of 6 mm and as such may not be suitable for use with all cable supports. However, fixings of the smallest available diameter (6mm) were used since it is assumed here that the diameter of the fixing should not impact on its performance if it was reduced to 4 mm.

Table 2 – Fixings used in the experiments

Number	Detail
Fixing 1	Countersunk 6 mm x 45 mm concrete screw
Fixing 2	Multipurpose twin thread countersunk zinc plated 4 mm x 40mm screw with 5 mm lightweight plastic wall plug
Fixing 3	Hammer-in fixing 6 mm x 40 mm; nylon plug with drive screw
Fixing 4	Multipurpose twin thread countersunk zinc plated 4 mm x 40mm screw with 6 mm medium weight nylon wall plug
Fixing 5	Sleeve anchor M6 x 40 mm medium weight use

Instrumentation

Each block was fitted with one Type K 1.0mm diameter steel sheathed thermocouple which was inserted approximately 50mm deep into the centre of the concrete block to measure the temperature of the concrete block and the approximate temperatures the fixings were exposed to from within the block. The thermocouple was inserted on the opposite surface of the block to the side the fixings were installed.

Experimental method

Two ovens were used for these experiments. One oven had a maximum temperature of 270°C and the other a maximum of 400°C.

Each block was exposed to one set temperature for one hour; i.e. one block was exposed to 100°C, another to 200°C, another to 300°C, and the fourth to 400°C.

The blocks exposed to 100°C and 200°C were placed in the oven with the lower maximum temperature. The other two blocks were exposed to 300°C and 400°C in the oven with the higher maximum temperature.



The ovens were pre-heated; each block was introduced into the oven once the oven had reached the desired temperature. After one hour's exposure, each block was removed from the oven and allowed to cool. The oven was then set to the new temperature and the next block was only placed inside after the oven had reached the desired temperature.

Once cool, the fixings were visually inspected for any failure that had not already become apparent upon opening the oven.

NOTE: For the purposes of this work, a fixing was considered to have failed when it fell out of the block into which it had been fixed.

Observations and findings

Cable supports experiments

Experiment 1

The duration of the fire was approximately 34 minutes. The maximum recorded temperature in the ISO room at ceiling height was 397°C, with a maximum recorded temperature at ceiling height approximately 1.8 metres from the ISO room (excluding lintels) of 302°C. After the experiment had been terminated and the rig was allowed to cool down, the condition of the cable supports was documented.

Table 3 details the average maximum temperatures observed at the lintels and hence at the cable supports and the condition of the cable supports after the first experiment. It can be seen from this table that all the metal supports used in the experiment were largely unaffected by the heat. The plastic clips, however, had failed on all four lintels and the cable could be seen to drop down. Also recorded in this table are the temperatures observed during the experiment when a cable was seen to drop from a lintel.

Table 3 – Summary of condition of cable supports after the first experiment with the average maximum temperatures recorded at each lintel

Lintel	Type	Average maximum temperature at lintel (°C)	Average temperature when cable observed to drop (°C)	Support 1	Support 2	Support 3	Support 4	Clip 5
1	Timber	264	258	All intact	All intact	All intact	All intact	Four failed
2	Concrete	294	286	All intact	All intact	All intact	All intact	All failed
3	Timber	255	243	All intact	All intact	All intact	All intact	All failed
4	Concrete	204	No drop	All intact	All intact	All intact	All intact	Four failed



Experiment 2

The duration of the fire was approximately 20 minutes. The maximum recorded temperature in the ISO room 0.5 metres from the ceiling was 820°C, with a maximum recorded temperature at the ceiling in the corridor approximately 1.8 metres from the ISO room (excluding lintels) of 690°C.

Table 4 details the average maximum temperatures observed at the lintels and hence at the cable supports and the condition of the cable supports upon inspection after the experiment.

NOTE: Average maximum temperature was determined by averaging the values recorded by each pair of thermocouples located at the lintels.

Similar to the first experiment, all the plastic clips on each lintel failed, resulting in the cable dropping down. A new observation from this experiment was that the supports in the centre of Lintel 2 had dropped out of the lintel. This was not a failure of the support but rather a failure of the plastic plugs used for fixing the supports to the lintel.

The supports which dropped out of Lintel 2 were recovered and found to be intact.

Table 4 – Summary of condition of cable supports after the second experiment with the average maximum temperatures recorded at each lintel

Lintel	Type	Average maximum temperature at lintel (°C)	Average temperature when cable observed to drop (°C)	Support 1	Support 2	Support 3	Support 4	Clip 5
1	Timber	578	481	All intact	All intact	All intact	All intact	All failed
2	Concrete	557	212 (Clip 5) and 221(Clip 2)	Three failed *	Three failed *	Three failed *	Three failed *	All failed
3	Timber	570	486	All intact	All intact	All intact	All intact	All failed
4	Concrete	388	310	All intact	All intact	All intact	All intact	All failed

* These failures were due to the plastic fixings in the lintel and not the supports themselves. The plastic plugs had melted resulting in the screws falling out of the lintel.

This second experiment was a more severe fire than the first experiment and flames did extend out of the ISO room reaching the end of corridor. Furthermore, the timber lintels were observed to smoulder during the experiment and there was a considerable amount of charring on both lintels. The insulation from the cables on Lintels 1 to 3 was consumed in the fire leaving the copper wiring mainly exposed (see Figure 6). The conduit and insulation on the cable within it was also fully consumed on these lintels but the wiring was contained within the supports. The polymeric coating on Clip 4 was consumed by the fire exposing the copper support underneath but this did not appear to have an effect on the integrity of the support.



Figure 6 - Comparison of the condition of cables and cable supports after the experiments (In both images the plastic clips have failed but the metal supports are intact)

Fixings experiments

Table 5 provides a summary of the conditions of the fixings after exposure to a set oven temperature for one hour. Visual observations were made on opening the oven but a more detailed inspection was not carried out until the block had cooled down.

Table 5 – Summary of condition of fixings after exposure to elevated temperatures and the maximum recorded temperatures in each concrete block

Oven temperature (°C)	Maximum temperature in block (°C)	Condition of each fixing				
		Fixing 1	Fixing 2	Fixing 3	Fixing 4	Fixing 5
100	58	Intact	Intact	Intact	Intact	Intact
200	104	Intact	Intact	Intact	Intact	Intact
300	100	Intact	Weakened	Intact	Intact	Intact
400	109	Intact	Weakened	Weakened	Failed	Intact



Discussion

Two experiments were carried out to assess the ability of a selection of five commercially available cable supports for electrical installations to maintain their integrity and hold electrical cabling in place when exposed to temperatures typically encountered in compartment fires. In addition, a series of bench-scale experiments was carried out using five types of commercially available fixings for cable supports for use in concrete substrates.

As this was a simple scoping study, only a small selection of cable supports was used and these were plastic and metal. Further work would be required to assess the effect of fire on cable supports composed of materials other than those used in these experiments.

Consideration would need to be given to the spacing of the cable supports; the spacing for these experiments was 0.3 m. However, a different spacing could be used, subject to manufacturers' recommendations. These experiments only used a single run of cable approximately two metres long in each row of cable supports but some of the supports used were designed to hold two runs of cable. Either of these conditions could introduce more load onto the support and further work is needed to assess the effect of this additional load on cable supports when exposed to elevated temperatures.

Five types of cable supports were selected for use in these experiments; one plastic clip and four metal cable supports. The plastic clips failed when exposed to hot gases and elevated temperatures associated with compartment fires. The four different metal supports remained intact after being subjected to hot gases and flames from the experimental fires and, would themselves, have prevented the cables from dropping down. The temperatures at which cables dropped due to failure of cable supports or fixings covered a wide range, from 212°C to 486°C. Any dropping of cable with metal supports was a result of fixing failure.

The findings from the short fixings study show that combustible wall plugs in concrete substrates demonstrate signs of weakening of mechanical strength from 300°C and above and that these fixings can fail at 400°C after up to a one hour exposure in controlled conditions. Non-combustible wall anchors and concrete screws were capable of retaining mechanical strength after exposure to 400°C for one hour in the same controlled conditions leading to the conclusion that there are commercially available products which can maintain their mechanical strength at that temperature.

The results of these experiments have also shown that cabling does not necessarily have to be contained in non-combustible cable management systems, i.e. a combustible conduit or other cable management system could be used provided that a non-combustible cable support, or a cable support which will maintain its mechanical strength when exposed to elevated temperatures, is used to hold the system in place in a suitable solid structure, with fixings which will maintain their mechanical strength when exposed to temperatures greater than 600°C.



Conclusions

This article has summarised the findings of a series of experiments to assess the effects of fire on a selection of cable supports and fixings. Obviously, the actual performance in a fire is dependent on the combination of the cable supports or clips and the fixings.

To prevent the risk of failure of cable supports during an incident, cable supports capable of maintaining their mechanical strength when exposed to temperatures greater than 600°C should be used.

There is a need for careful consideration in the selection of fixings for any cable support and based on these findings, wherever possible, fixings which will maintain their mechanical strength when exposed to temperatures greater than 600°C should be used if the risk of failure of the support is to be avoided. This programme of work demonstrated that there are commercially-available fixings capable of withstanding up to 400°C.

It is possible to use combustible conduit and cable management systems however they need to be installed with non-combustible supports and fixings which can maintain mechanical strength when exposed to temperatures greater than 600°C to prevent cables from dropping down.

Overall, this series of experiments has shown that quite simple and readily available supports and fixings which are capable of withstanding temperatures greater than 600°C can be sufficient to avoid cables falling when exposed to typical compartment fires.

References

1. The Coroner's Rules 1984, SI 1984 No 552.
2. Inquest into Harrow Court – Findings. Rule 43 Harrow Court Letter. Published by Fire Brigades Union.
Available at:
http://www.fbuberkshire.co.uk/wp-content/uploads/2011/01/Harrow_Court_5_Findings_Rule43_Letter.pdf. Last accessed 10th October 2013.
3. BS 5839-1:2002 Fire detection and fire alarm systems for buildings. Code of practice for system design, installation, commissioning and maintenance, British Standards Institution.
4. Chief Fire Officers Association (CFOA) Services Website, Operational Bulletins at:
<http://www.cfoa.org.uk/12134>. Last accessed 30th September 2013.
5. Appendix O of the Report of the Hampshire Fire and Rescue Service investigation into the deaths of Firefighters Alan Bannon and James Shears in Flat 72, Shirley Towers, Church Street, Southampton, SO15 5PE, on Tuesday 6 April 2010.

Available at: <http://www.hantsfire.gov.uk/shirleytowers.pdf>. Last accessed 10th October 2013.



6. BS 7671:2008: Requirements for electrical installations. IET Wiring Regulations Seventeenth Edition, Institution of Engineering and Technology and British Standards Institution, 2008.
7. BS 476-33:1993, ISO 9705:1993 Fire tests on building materials and structures. Full scale room test for surface products, British Standards Institution, 1993.
8. BS EN 520:2004+A1:2009 Gypsum plasterboards. Definitions, requirements and test methods, British Standards Institution, 2004.
9. BS 476-6:1989+A2:2009 Fire tests on building materials and structures. Method of test for fire propagation for products, British Standards Institution, 1989.
10. BS 476-7:1997 Fire tests on building materials and structures. Method of test to determine the classification of the surface spread of flame of products, British Standards Institution, 1997.
11. UL 94 Tests for Flammability of Plastic Materials for Parts in Devices and Appliances, Underwriters Laboratories, 2013.

Acknowledgements

The research on which this article is based was commissioned by the Department for Communities and Local Government (DCLG) and carried out by BRE. Any views expressed are not necessarily those of DCLG, with whose permission the article is published.